

FIRE RESISTANT METAL CABINET

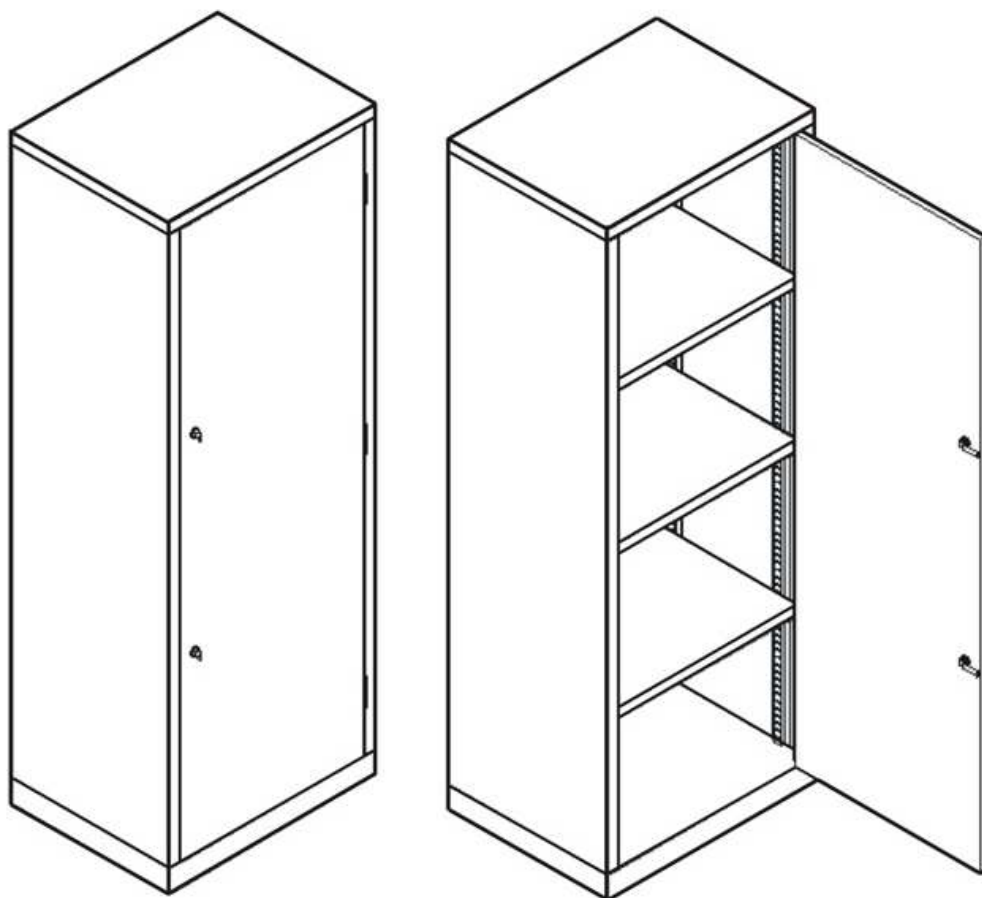

DESCRIPTION

FIRE RESISTANT METAL CABINET

Code: **FRMC**

HEIGHT ADJUSTABLE SHELVES

2 KEY LOCKS

OUTSIDE DIMENSIONS: 62W x 49D x 183H

INSIDE DIMENSIONS: 59W X 45D X 175H

Weight: 150 kg

Price: € 980.00 + VAT (=€ 1166.20)

SAFES 16

Ref. V043