

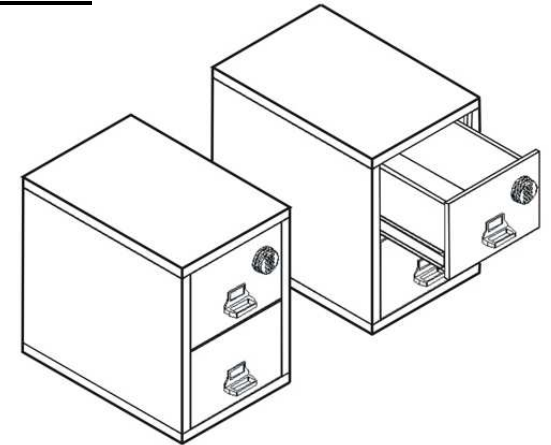

VIOMETAL FIRE PROOF FILING CABINETS

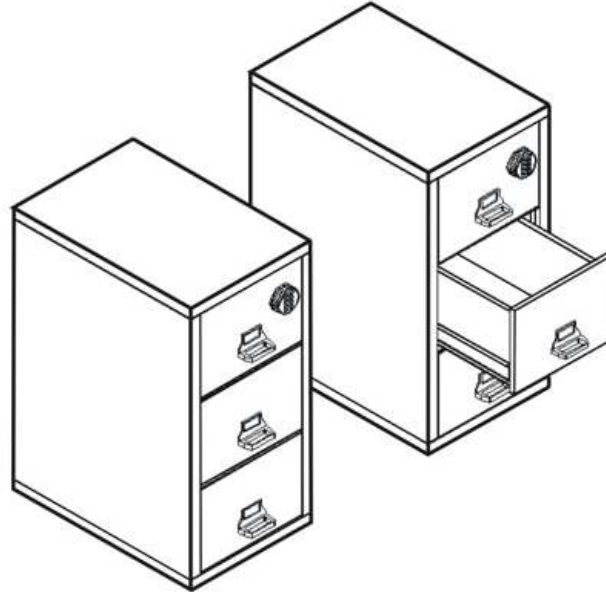
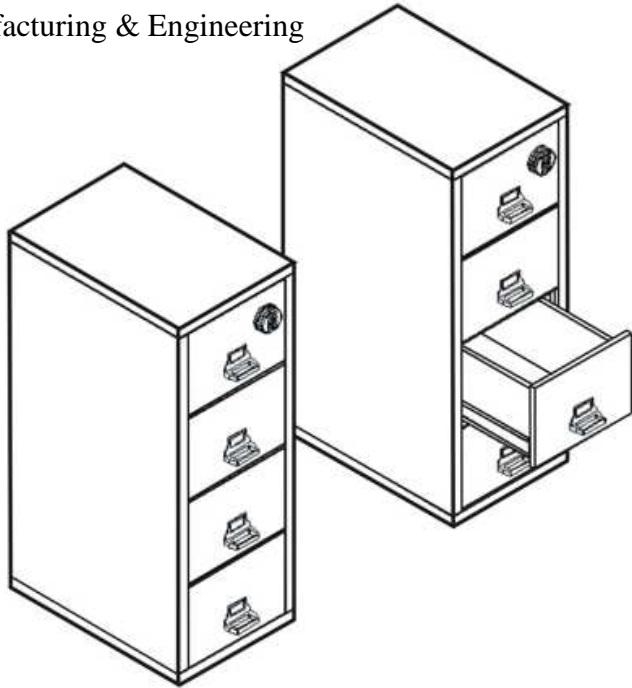

- 100% Gypsum. Reinforced body
- S&G Electronic Lock
- Environmentally Friendly Powder Coating Paint

CODE	WIDTH IN mm	DEPTH IN mm	HEIGHT IN mm	DESCRIPTION	PRICE
FFC2/E	540	800	760	Viometal Fireproof Cabinets –2Drawers	€1,800.00+VAT (€2142.00)
FFC3/E	540	800	1100	Viometal Fireproof Cabinets –3 Drawers	€2055.00+VAT (€2,445.45)
FFC4/E	540	800	1450	Viometal Fireproof Cabinets –4 Drawers	€2220.00+VAT (€2,641.80)

▪ **Prices do not include any additional costs for forklift lifting expenses.**



SAFES 10-12

Ref: V007